

FAST DATA TRANSMISSION AND DATA CONFIDENTIALITY USING LI-FI TECHNOLOGY IN GOLD MINING & GOLD ORING PROCESS USING VLC

Kovuru Divya,

Final Year UG Student, ECE, Panimalar Institute of Technology, Chennai, India

M.Mugeswari,

Final Year UG Student, ECE, Panimalar Institute of Technology, Chennai, India

Pattapu Roja Sri,

Final Year UG Student, ECE, Panimalar Institute of Technology, Chennai, India

M.Jhansi Rani

Assistant Professor, ECE, Panimalar Institute of Technology, Chennai, India

Abstract— We give the answer for the issue in the gold mining and oring forms. Gold mining and oring includes the science, innovation, and business of the revelation of gold, notwithstanding its expulsion and deal in the commercial center. Most wounds underground include falling rock, slips, and blasts. Lethal gas is discharged amid the time of mining and oring forms. The mining specialists were influenced by lung sickness by breathing in tidy and poisonous gas in Gold mining condition. This proposed framework screens lethal gas in the natural, gauges the changes in gold mining utilizing different sensors. Light loyalty (Li-Fi) innovation is acquainted with gauge the checked information. In this Light devotion innovation, we can information transmission and gathering in a risk less way.

Keywords-component; formatting; style; styling; insert (key words)

I. INTRODUCTION

Wi-Fi innovation turns out to be more well known today. Each open spots and private workplaces have Wi-Fi as a result of this remote range is blocked habitually. Because of most extreme utility RF obstructions are getting more basic to conquer this issue light constancy (Li-Fi) innovation was presented in the year 2011. Li-Fi is comparative to different remote correspondence which utilizes the correspondence medium as light. Noticeable light is use to exchange information between the framework rather than radio signs. Li-Fi utilizes LED light source to transmit the information remotely this technique is generally called as VLC (unmistakable light correspondence). A surge of information transmitted in the method for beats of light that can't be recognized by the bare eye. By utilizing the Li-Fi innovation numerous enhancements are done in the field of mechanization. In this work the Li-Fi is utilized for shrewd home where the information's of the sensors are gotten and transmitted to the next end with the assistance of obvious light.

The information is sent in the method for light beams that has been created utilizing LED light source the force of the light source as been expanded by decreasing the adequacy of the computerized information that as to be transmitted. The parts utilized into the Li-Fi correspondence reasons for existing are Led lights or rich light source and the photograph indicator. A photograph identifier can be utilized to get the transmitted information from the light source and produces the unique information. In this we are proposing a wellbeing framework for the mining laborers to maintain a strategic distance from minor or real mishaps and to spare the life of the specialists. The CH₄ sensor is utilized to detect the level of methane gas display in the mine and to suggest the authorities about the nearness of risky gas. In the event that so discovered it can be demonstrated by an alert and if the level surpasses it can be depleted by utilization of a fumes fan. The beat oxi is utilized to screen the pulse of the specialist what's more, these information's are transmitted to the checking area through VLC. In the gold oring process the dangerous level is detected by pH sensor and showed in the LCD and if the harmful level surpasses the limit esteem the Sodium Meta Sulfate dissolvable is showered over the region to kill the harmful level. The got information is transmitted by the noticeable light and got by the photograph finder at the collector end and after that it is transmitted to the PC and observed at the recipient area. The above work is done to upgrade the wellbeing for the mining specialists styles are provided. The formatter will need to create these components, incorporating the applicable criteria that follow.

II. LITERATURE SURVEY

Serhan Yarkan, Sabih G`uzelg`oz, H`useyin Arslan, and Robin R. Murphy[1] suggested that After a current arrangement of lappalling underground mining catastrophes, the essential significance of interchanges for underground mining is underlined once again. Building up solid correspondence is an extremely troublesome undertaking for underground mining due to the extraordinary natural conditions. As of recently, no single correspondence framework exists which can settle all of the issues and challenges experienced in underground mine interchanges. In any case, consolidating research with past encounters may help existing frameworks enhance, if not totally take care of the majority of the issues. In this study, underground mine correspondence is investigated..M. Donoghue[2] depicted that the physical, compound, natural, ergonomic and psychosocial word related wellbeing perils of mining and related metallurgical forms. Mining remains a critical modern segment in many parts of the world and albeit significant advance has been made in the control of word related wellbeing dangers, there remains space for further hazard decrease. Kiran Lakkaraju, William Yurcik and Adam J. Lee [4] portrayed that The quantity of assaults against vast PC frameworks is as of now developing at a fast pace. Notwithstanding the best endeavors of security examiners, substantial associations are experiencing difficulty continuing top of the present condition of their systems. In this paper, we depict an instrument called NVisionIP that is intended to build the security investigator's situational mindfulness. As people are intrinsically visual creatures, NVisionIP utilizes a graphical portrayal of a class-B system to permit investigators to rapidly imagine the current condition of their system. We show an outline of NVisionIP alongside an exchange of different sorts of security-related situations that it can be utilized to identify. Sarah Vieweg, Amanda L. Hughes, Kate Starbird and Leysia Palen[5] investigated the microblog posts created amid two later, simultaneous crisis occasions in North America through Twitter, a well known microblogging administration. We concentrate on correspondences communicate by individuals who were "on the ground" amid the Oklahoma Grassfires of April 2009 and the Red River Floods that happened in March and April 2009, and distinguish data that may add to upgrading situational mindfulness (SA). This work intends to educate next strides for separating helpful, pertinent data amid crises utilizing data extraction (IE) procedures.:

III. FRAMEWORK ARCHITECTURE

Mankind has been using light as a correspondence medium for a long time, and light keeps on being of incredible advantage in the field of correspondence. Fire has been utilized to make smoke motions on mists; that is a sort of visual correspondence. After the development of the electric light by Thomas Alva Edison in the nineteenth century, new ways were created to utilize light to impart. The innovation of the electric globe prompted to the development of the Flag Lamp, a visual flagging gadget utilized for optical correspondence concocted by Arthur C. W. Aldis. Ordinarily, the Signal Lamp utilizes Morse code to offer data to the spectator by making shades mounted on the front of the light open and close. The mining area comprises of the accompanying primary segments. CH4 Sensor, Heartbeat sensor, ADC, AT89S52 microcontroller, LCD show, Exhaust fan and VLC transmitter.

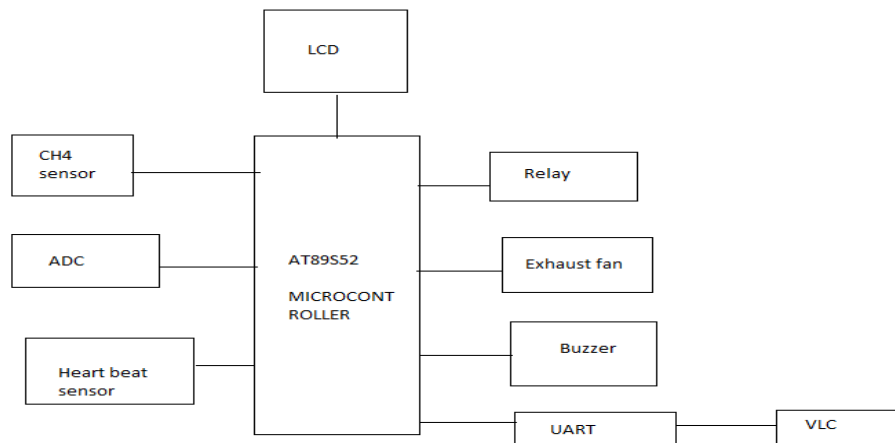

The AT89S52 is a low-control, elite CMOS 8-bit smaller scale controller with 8K bytes of in-framework programmable Flash memory. It is totally good with MSC-51 items. The gadget is fabricated utilizing Atmel's high-thickness non-unpredictable memory innovation and is perfect with the Indus-trystandard 80C51 guideline set and stick out. The on-chip Flash permits the program memory to be reconstructed insystem on the other hand by an ordinary non-unpredictable memory genius language structures. By joining a flexible 8-bit CPU with insystem programmable Flash on a solid chip, the Atmel AT89S52 is an effective microcontroller which gives a very adaptable and savvy answer for some implanted control applications. The AT89S52 gives the taking after

standard elements has 8K bytes of Flash and 256 bytes of RAM with 32 I/O lines, Watchdog clock, two information pointers, three 16-bit clock/counters, a six-vector two-level interfere with design, a full duplex serial port, on-chip oscillator, what's more, clock hardware. What's more, the AT89S52 is outlined with static rationale for operation down to zero recurrence and bolsters two programming selectable power sparing modes.while permitting the RAM the idle mode stops the cpu.clock/counters, serial port, and interfere with framework to keep working. The Power-down mode spares the RAM substance however solidifies the oscillator, impairing all other chip capacities until the following hinder or equipment reset.

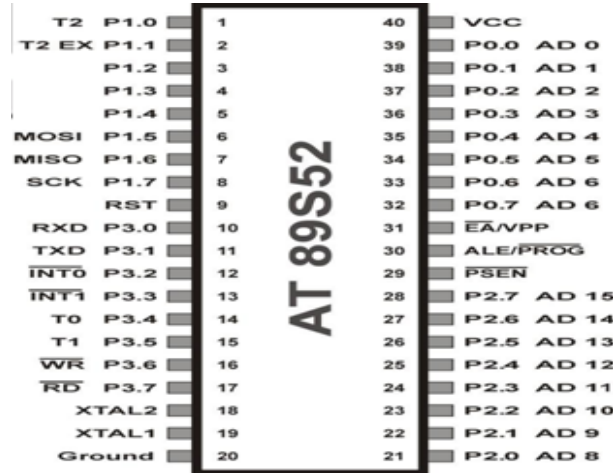

The ADC0808, ADC0809 information securing part is a solid CMOS gadget with a 8-bit simple to-computerized converter, 8-channel multiplexer and chip perfect control rationale. The 8-bit A/D converter utilizes progressive estimation as the change procedure. The converter highlights a high impedance chopper balanced out comparator, a256R voltage divider with simple switch tree and a progressive guess enroll. The 8-channel multiplexer can straightforwardly get to any of 8-single-finished simple signs. The gadget kills the requirement for outside zero and full-scale conformities. Simple interfacing to microchips is given by the locked furthermore, decoded multiplexer address inputs and hooked TTL TRI-STATE yields.

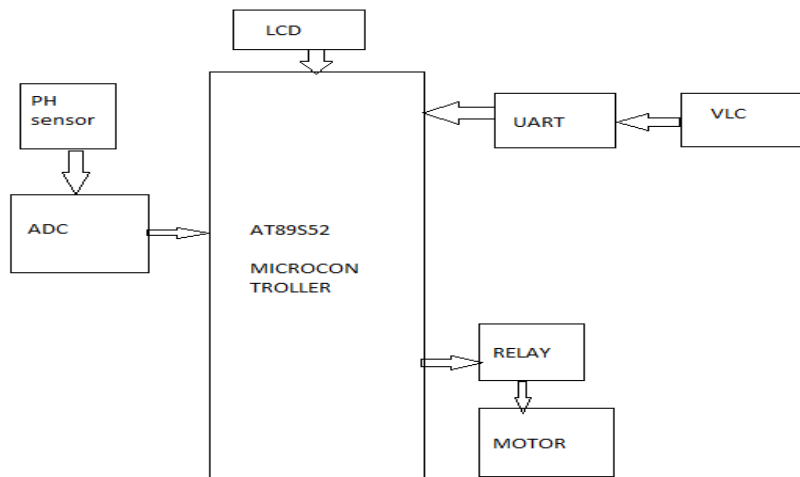

A pH meter measures the potential contrast (in mV) between the terminals and believers it to a show of pH. In request to get a right estimation, the info intensifier and the changing over circuit must meet certain prerequisites. The potential contrast between the reference terminal and the glass anode is opened up in the mV intensifier before the A/D converter bolsters the flag to the chip for result count. As the glass cathode regularly has an internal resistance of the request of 108ω , the enhancer's information resistance, R_i , must be impressively higher. An estimation of 10^{12} is required. For a similar reason it is additionally critical that the intensifier does not send any current through the glass terminal as this will give a mistake potential and could even bother the cathode. The yield is an advanced flag for the numeric show. In an advanced pH meter, the enhancer works under the same conditions constantly and is specifically associated with an A/D converter

The measured voltage can be expressed by the Nernst equation in the following way:

$$E = E_{ind} - E_{ref} = E^{\circ}T - R \cdot T/F \cdot \ln aH^{+}$$

Where,

E = Measured voltage (mV)

E_{ind} = Voltage of indicator electrode (mV)

E_{ref} = Voltage of reference electrode (mV)

$E^{\circ}T$ = Temperature dependent constant (mV)

R = Gas Constant (8.3144 J/K)

T = Absolute Temperature (K)

F = Faraday's constant (96485 C)

The bells used are FDK piezoelectric signals produce sound through the twisting vibrations of a thin metal plate clung to a piezoelectric component. These signals highlight low power consumption, a safe, stop-free and non-contact structure, and a shopping center size and light weight for an easy mounting to printed circuit sheets.

A hand-off is an electrical switch that uses an electromagnet to move the switch from the off to on position instead of a person moving the switch. It takes a moderately shopping center measure of energy to turn on a hand-off however the hand-off can control something that draws a great deal more power. The VLC part of the gadgets suggests changes over these signals into light signals based ON-OFF encoding.

CPU is a unit which screens and controls all procedures inside the microcontroller and the client can't influence its work. It comprises of a few smaller subunits, of which the most critical are: Instruction decoder is a piece of the gadgets which perceives program directions and runs different circuits on the premise of that. The capacities of this circuit are communicated in the "direction set" which is distinctive for each microcontroller family. Arithmetical Logical Unit (ALU) plays out all numerical and sensible operations upon information. Register is an SFR firmly identified with the operation of ALU. It is a sort of working work area utilized for putting away all information whereupon a few operations ought to be executed (expansion, move and so forth.). It likewise stores the outcomes prepared for use in further handling.

One of the SFRs, called the Status Register, is firmly identified with the register, appearing at any given time the "status" of a number put away in the register (the number is more noteworthy or under zero and so forth.). A bit is only a word developed to befuddle fledglings at hardware. Kidding aside, this word by and by shows whether the voltage is available on a conductor or not. On the off chance that it is exhibit, the fitting pin is set to rationale one (1), i.e. the bit's esteem is 1. Something else, if the voltage is 0 V, the fitting pin is cleared (0), i.e. the bit's esteem is 0. It is more convoluted in principle where a bit is alluded to as a twofold digit, however even for this situation, its esteem can be either 0 or 1.

Using light as a correspondence medium was actualized by Alexander Graham Bell in 1880 with his development of the photo phone, a gadget that transmitted a voice motion on a light emission. Ringer centered daylight with a mirror and afterward talked into an instrument that vibrated the mirror. The vibrating shaft was gotten by the identifier at the less than desirable end and decoded once more into the voice flag, an indistinguishable system from the telephone did with electrical signs. In any case, Bell couldn't create a helpful bearer recurrence, nor was he ready to transmit the light pillar from indicate point. Deterrents in nature, for example, haze and rain — which could meddle with the photo phone — made Bell stop any future research into his creation. With the creation of LED (Light Emitting Diode), utilizing light as a correspondence medium has begun once more. VLC utilizes white Light Emitting Diodes (LED), which send information by blazing light at speeds imperceptible to the human eye. One noteworthy favorable position of VLC is that we can utilize the framework around us without making any progressions to it. LEDs' capacity to exchange data motions over (light which is between 400THz to 800THz of recurrence and whose wavelength is between 400nm to 700nm) makes it a decent correspondence medium. Presently the light we use in our day by day life can be utilized for giving light as well as to correspondence.

Clocks utilize most projects which utilize these smaller than normal electronic "stopwatches" in their operation. These are regularly 8-or 16-bit SFRs the substance of which are naturally increased by each coming heartbeat. Once the enlist is totally stacked, a hinder is created! In the event that these registers utilize an inside quartz oscillator as a clock source, then it is conceivable to quantify the time between two occasions (if the enroll esteem is T_1 right now estimation has begun, and T_2 right now it has completed, then the slipped by time is equivalent to the aftereffect of subtraction $T_2 - T_1$). On the off chance that the registers utilize beats originating from outer source, then such a clock is transformed into a counter. This is just a basic clarification of the operation itself. It's by one means or another more entangled practically speaking. Programs executed are distinctive here, not at all like other coordinated circuits which just should be associated with different segments

and turn the power supply on; the microcontrollers should be modified first. This is a purported "astringent pill" and the principle motivation behind why equipment arranged gadgets engineers avoid microcontrollers. It is a trap bringing on enormous misfortunes in light of the fact that the way toward programming the microcontroller is essentially exceptionally basic. With a specific end goal to compose a program for the microcontroller, a few "low-level" programming dialects can be utilized, for example, Assembly, C and Basic. Composing program system comprises of straightforward written work directions in the request in which they ought to be executed.

Hinder - gadgets is generally quicker than physical procedures it ought to monitor. This is why the microcontroller invests the greater part of its energy sitting tight to something to happen or execute. As it were, when some occasion happens, the microcontroller accomplishes something. With a specific end goal to keep the microcontroller from spending a large portion of its time unendingly checking for rationale state on info sticks and registers, a hinder is produced. It is the flag which illuminates the focal processor that something consideration commendable has happened. As its name recommends, it interferes with general program execution. It can be produced by various sources so when it happens, the microcontroller promptly stops operation and checks for the cause. On the off chance that it is required to play out a few operations, a present condition of the program counter is pushed onto the Stack and the fitting program is executed. It's the alleged intrude on schedule. Stack is a piece of RAM utilized for putting away the present condition of the program counter (address) when a hinder happens. Along these lines, after a subroutine or an intrude on execution, the microcontroller knows from where to proceed with standard program execution. This address is cleared in the wake of coming back to the program in light of the fact that there is no compelling reason to spare it any more, and one area of the stack is consequently accessible for further utilize. What's more, the stack can comprise of a few levels. This empowers subroutines' settling, i.e. calling one subroutine from another.'

IV. EXAMINATION OF WI-FI WITH LI-FI

Considerers demonstrate that Wi-Fi being the quickest exchange known to a typical man gives a high information exchange rate and snappy usage speed. Be that as it may, in Li-Fi the information is exchanged through the speed of light which is quicker than the ordinary information move rate in the Wi-Fi transmission. Li-Fi can be utilized as a part of an ordinary domain. In any case, in a domain which emanates harmful gasses the Wi-Fi gives a radiation which joins and gives an exceptionally unsafe harmful emanation that would influence the human life display in the encompassing and also the general population coming in contact. So to maintain a strategic distance from this jeopardizing impact, we furnish with Li-Fi transmission and furthermore give a strategy for transmission that doesn't influence any human individual who comes into contact with the gas or with whatever other human.

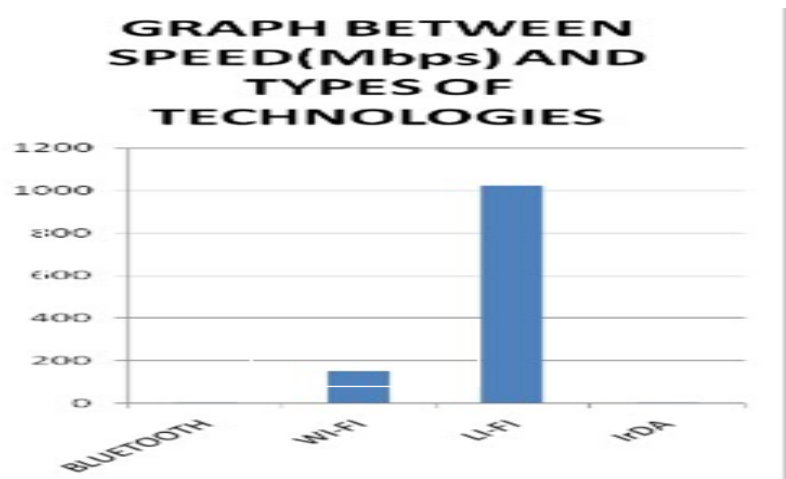

V. MODULES DESCRIPTION

A. MODULE 1:CH4 SENSOR

This part in the mining segment is utilized to distinguish raised levels of methane or other dangerous gasses in the neighborhood condition. Upon identification it sends a flag which enacts the ringer and the fumes fan set up. The signal cautions the specialists to the nearness of dangerous gasses noticeable all around and the fumes fan keeps the lethality noticeable all around to a fair level while the specialists empty the premises. The CH 4 sensor detects the force of the gas that is applied on the area and sends the flag through light to the beneficiary, which thus causes the ringer to ring at the point when the force is high. At the point when the power and the poisonous quality is low in the applied gas the estimations of the gas lessens furthermore, furnishes with an ostensible estimation of yield for computation.

B. MODULE 2: HEARTBEAT SENSOR

The pulse sensor is joined onto every individual specialist and continually screens their heartbeat rate. The model we use in the venture for show is hardwired to refresh the recorded heartbeat rate in the event that it is steady for 10 ticks, if not it holds up till it gets a reliable perusing to give a precise esteem. In the model if the pulse drops or rises over the limit levels, it will actuate the bell. In the continuous execution the pulse sensor is connected to the client with a radiating LED light the enlightens with a supercharged battery for getting the pulse of the laborer at regular intervals. At the point when the pulse spikes increasingly the 72 beats for every moment and on the off chance that it is more than 72, the signal seems to ring showing that the individual is under threat conditions.

C. MODULE 3: PH SENSOR

The pH sensor in the oring parts is utilized to identify any leftover dangerous segments discharged when the gold is extricated from the mineral. The resistance level of pH for human skin is 6-8. Anything higher or lower will bring about distress and in extraordinary cases, bursting, draining and changeless harm. The pH sensor is moduled with 2 consequent poles that are embedded into the stones which contains with gold and harmful gasses. This distinguishes the dangerous gasses and furnishes with the esteem that it needs to trigger the bell.

D. MODULE 4: TRANSMITTER AND RECEIVER UNIT

The transmitter unit changes over every one of the information gathered from the different sensor units a d transmits it to the beneficiary by means of visual light correspondence and got utilizing photograph diode. It changes over the electrical signs into light flags by utilize of on-off encoding and uses the baud rate recurrence which is preset into both beneficiary and transmitter to guarantee information privacy. The transmitter is associated with the LED light which emanates the light to the beneficiary. Here the light is lit up by a high force light which allots the recurrence and exchanges to the recipient that has the same recurrence.

VI. PROFICIENCY OF THE SYSTEM

Considers demonstrate that Wi-Fi being the quickest exchange known to a typical man gives a high information exchange rate and snappy usage speed. Be that as it may, in Li-Fi the information is exchanged through the speed of light which is quicker than the ordinary information move rate in the Wi-Fi transmission. Li-Fi can be utilized as a part of an ordinary domain. In any case, in a domain which emanates harmful gasses the Wi-Fi gives a radiation which joins and gives an exceptionally unsafe harmful emanation that would influence the human life display in the encompassing and also the general population coming in contact. So to maintain a strategic distance from this jeopardizing impact, we furnish with Li-Fi transmission and furthermore give a strategy for transmission that doesn't influence any human individual who comes into contact with the gas or with whatever other human.

VII. FRAMEWORK IMPLEMENTATION

Li-Fi being executed in the field of digging for wellbeing of the specialists is particularly successful since the mine shafts is a shut space and almost no surrounding light or regular light sources are accessible and a lot of simulated light sources are required to be introduced. We can use these light hotspots for our system and due to the nonattendance of other light sources, we don't have to put much in optical or wavelength channels. Additionally since the mineshafts won't be more than 10-20 feet long, we light force required is very low permitting us to expend less power. Thus in our set up we show the working of the modules and correspondence of up to 10 feet in a shut domain.

VIII. CONCLUSION

Our venture gives security framework to Gold Mining people utilizing Visible Light Communication. Li-Fi (Light Loyalty) as a quick and shabby optical variant of Wi-Fi. The fundamental parts of this correspondence framework are high shine white LED, Which goes about as a correspondence source and silicon photograph diode which demonstrates great reaction to obvious wavelength locale. filling in as the getting component. Here CH4 sensor is utilized to detect the level of methane gas display in the mine and to imply the authorities about the nearness of unsafe ga s. On the off chance that so discovered it can be shown by a caution and if the level surpasses it can be depleted by utilization of a fumes fan. The Heart beat sensor is used to screen the heart beat of the specialist and these information are transmitted to the checking area through VLC.

REFERENCES

- [1] Underground Mine Communications: A Survey Serhan Yarkan, Sabih G̃uzelg̃oz, H̃useyin Arslan, and Robin R. Murphy.
- [2] Occupational health hazards in mining: an overview M. Donoghue .
- [3] NVisionIP: NetFlow Visualizations of System State for Security Situational Awareness Kiran Lakkaraju, William Yurcik and Adam J. Lee .
- [4] Microblogging during Two Natural Hazards Events: What Twitter May Contribute to Situational Awareness Sarah Vieweg, Amanda L. Hughes, Kate Starbird & Leysia Palen analyzed.
- [5] Cooperative Forest Fire Surveillance Using a Team of Small Unmanned Air Vehicles David W. Casbeer, Derek B. Kingston, Randal W. Beard, Timothy W. McLain Sai-Ming Li, Raman Mehra .
- [6] IEEE Standard for Local and Metropolitan Area Networks--Part15.7: Short-Range Wireless Optical Communication Using Visible Light, pp. 1–309, Sept.2011.
- [7] T. Komineand M. Nakagawa —Integrated system of white LED visible-light communication and power-line communication, IEEE Trans. Consume. Electron, vol. 49, pp. 71–79, Feb. 2003.
- [8] M.Saadi, L. Wattisuttikulij, Y. Zhao, P. Sangwongngam, —Visible Light Communication: Opportunities, Challenges and Channel Models, International Journal of Electronics and Informatics, vol. 2, Feb.2013.
- [9] Jang—Mitigation Technique for Receiver Performance Variation of Multi-Colour Channels in Visible Light Communication, Sensors Journal, vol.11, pp.6131-6144, Jun.2011.
- [10] S. Kim, J.S Won, S.H Nahm, —Simultaneous Reception of Visible Light Communication and Optical Energy using a Solar Cell Receiver, ICT convergence (ICTC), pp.896-897, Oct.2013.
- [11] S.Haruyama, —Advances in Visible Light Communication Technologies, ECOC Technical Digest, 2012.
- [12] M.Syuhaimi Ab-Rahman, L. Al-Hakim Azizan, H.Ramza and Z. Musa, —The Comparison of Experimental and Analytical Study of The Gaussian Intensity.